



V  
THE VALLEY

EDEN



-  SPRUCE
-  IRIS
-  MAY BELL

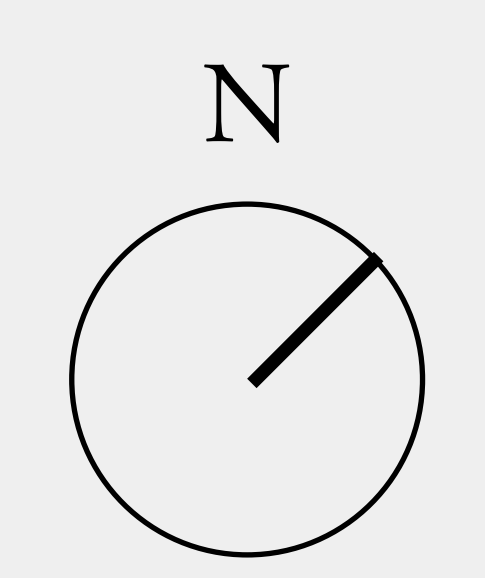

FLOOR PLAN 1. All dimensions are in imperial and metric, and measured from finish to finish excluding construction tolerances. 2. All materials, dimensions, and drawings are approximate only. 3. Information is subject to change without notice, at developer's absolute discretion. 4. Actual area may vary from the stated area. 5. Drawings not to scale. 6. All images used are for illustrative purposes only and do not represent the actual size, features, specifications, fittings, and furnishings. 7. The developer reserves the right to make revisions / alterations, at it's absolute discretion, without any liability whatsoever.

  
THE VALLEY

EDEN

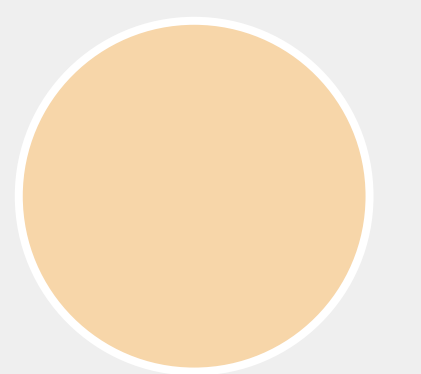

SPRUCE

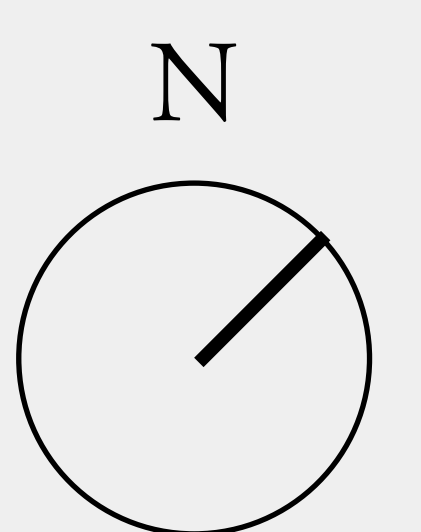

FLOOR PLAN 1. All dimensions are in imperial and metric, and measured from finish to finish excluding construction tolerances. 2. All materials, dimensions, and drawings are approximate only. 3. Information is subject to change without notice, at developer's absolute discretion. 4. Actual area may vary from the stated area. 5. Drawings not to scale. 6. All images used are for illustrative purposes only and do not represent the actual size, features, specifications, fittings, and furnishings. 7. The developer reserves the right to make revisions / alterations, at it's absolute discretion, without any liability whatsoever.

**THE VALLEY**

**EDEN**

SPRUCE  
3 BEDROOM 1 A

UNIT	TOTAL AREA	
8 PLEX - TH 02	1937.39 SQFT	179.99 SQM
8 PLEX - TH 04	1929.75 SQFT	179.28 SQM
8 PLEX - TH 06	1929.75 SQFT	179.28 SQM

KEY PLAN

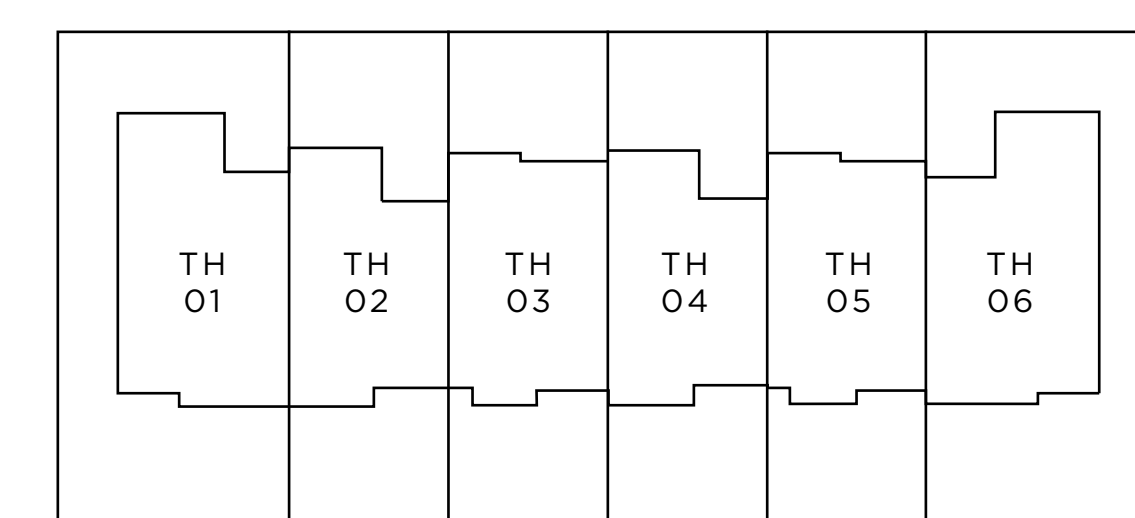

6 PLEX  
STREET SIDE

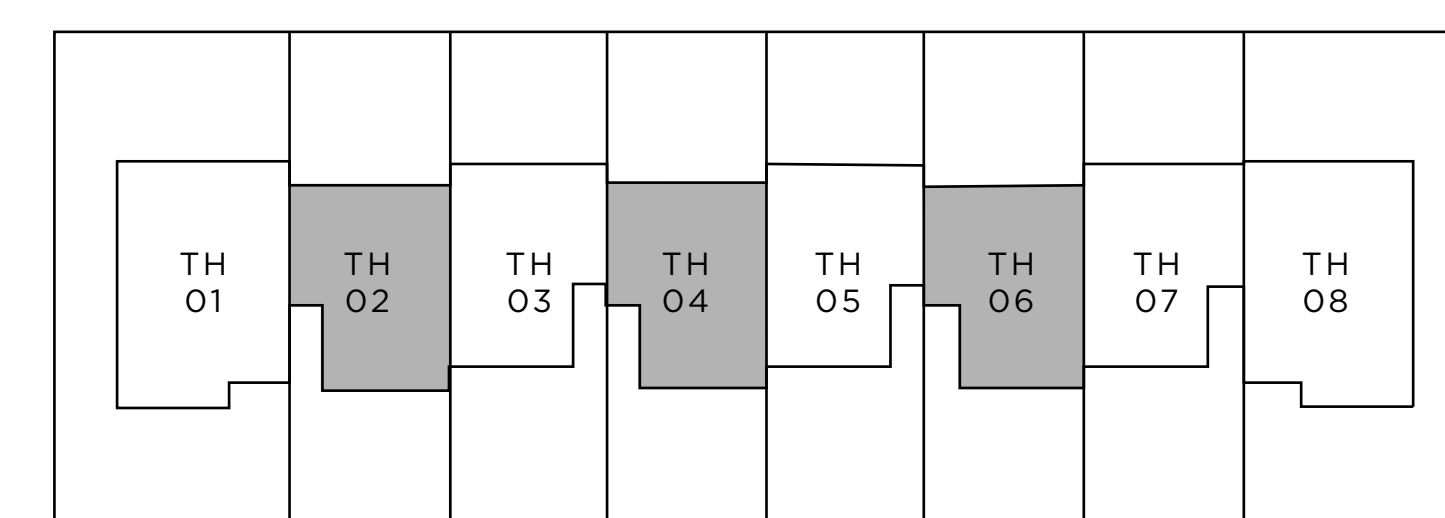

8 PLEX  
STREET SIDE

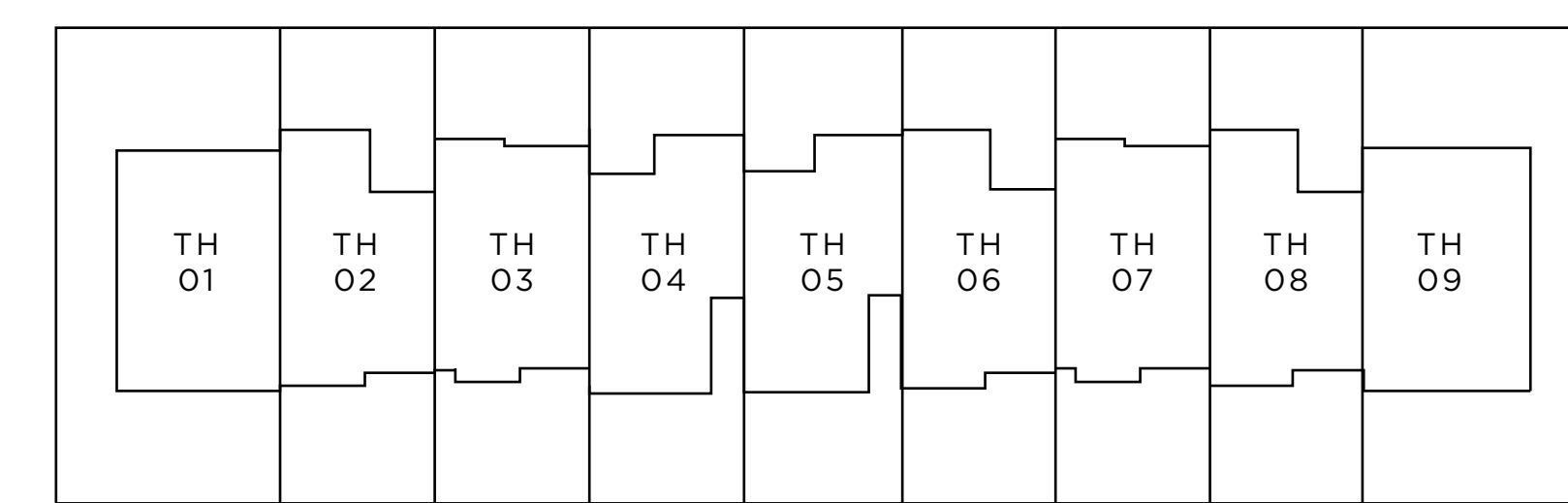

9 PLEX  
STREET SIDE

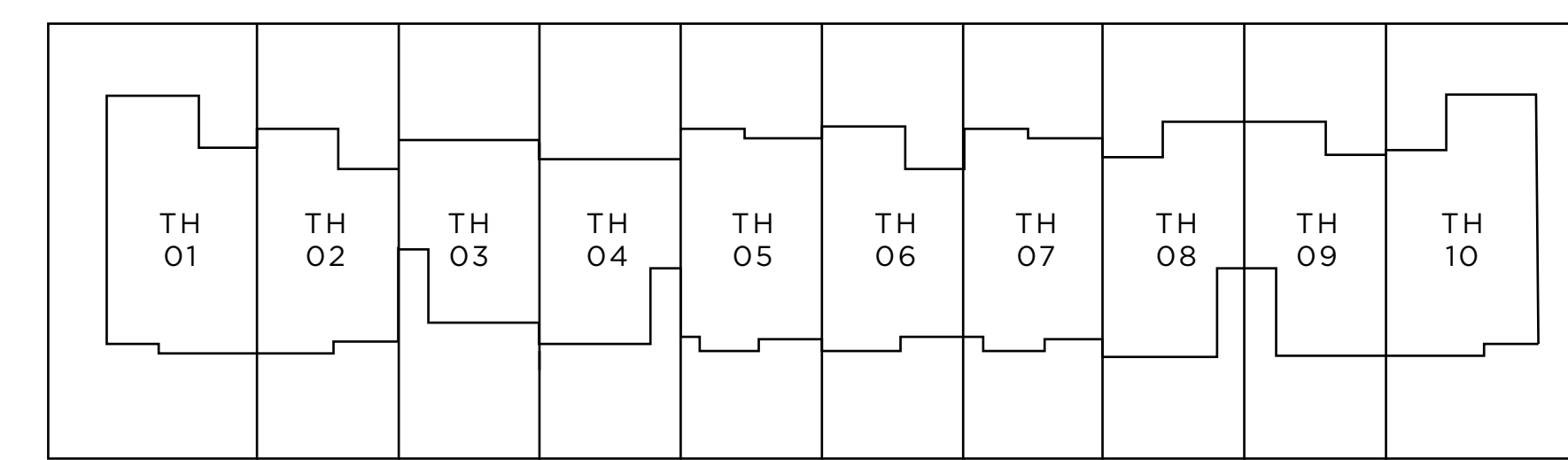

10 PLEX  
STREET SIDE

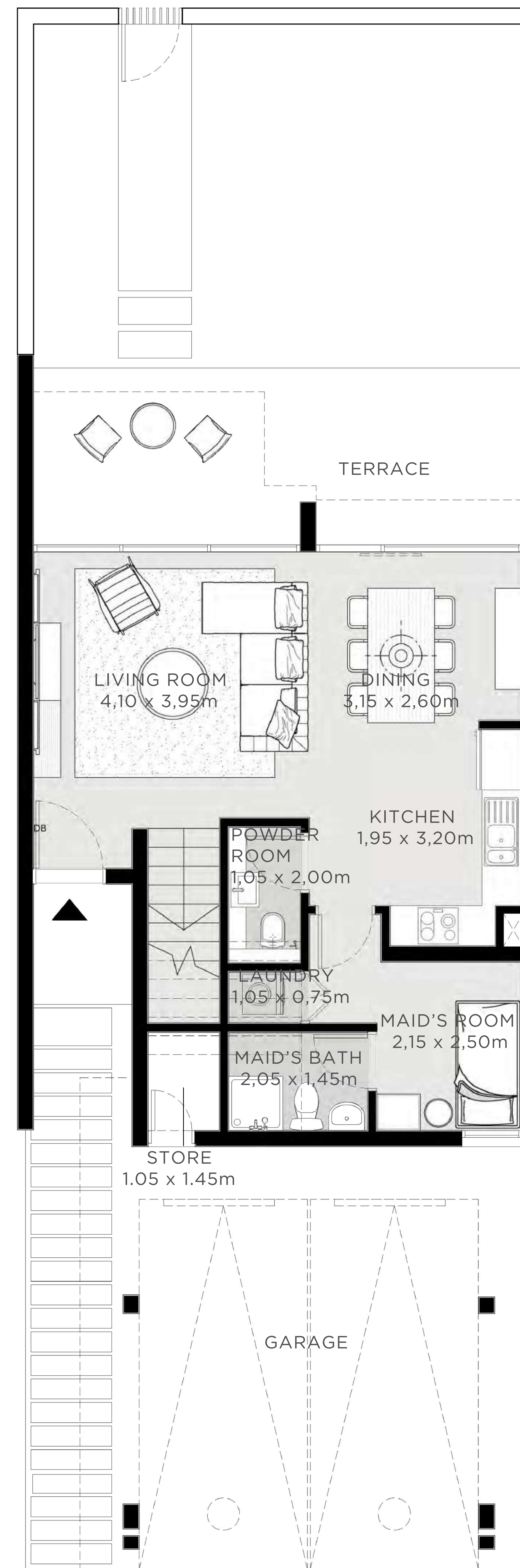

GROUND FLOOR



FIRST FLOOR

FLOOR PLAN 1. All dimensions are in imperial and metric, and measured from finish to finish excluding construction tolerances. 2. All materials, dimensions, and drawings are approximate only. 3. Information is subject to change without notice, at developer's absolute discretion. 4. Actual area may vary from the stated area. 5. Drawings not to scale. 6. All images used are for illustrative purposes only and do not represent the actual size, features, specifications, fittings, and furnishings. 7. The developer reserves the right to make revisions / alterations, at it's absolute discretion, without any liability whatsoever.

# THE VALLEY

## EDEN

### SPRUCE 3 BEDROOM 1 B

UNIT	TOTAL AREA	
8 PLEX - TH 03	1988.41 SQFT	184.73 SQM
8 PLEX - TH 05	1988.41 SQFT	184.73 SQM
8 PLEX - TH 07	1996.81 SQFT	185.51 SQM

#### KEY PLAN

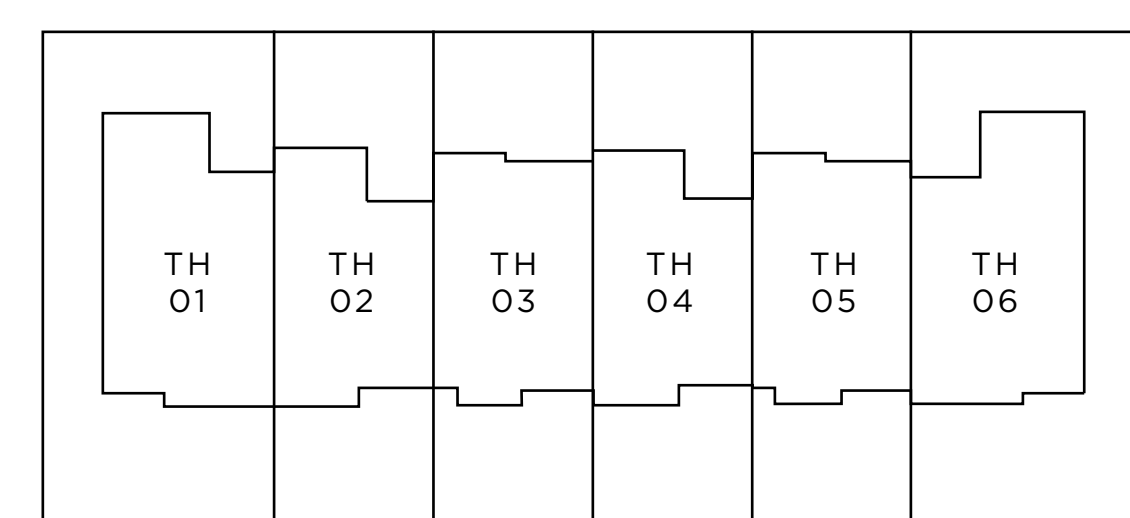

6 PLEX  
STREET SIDE

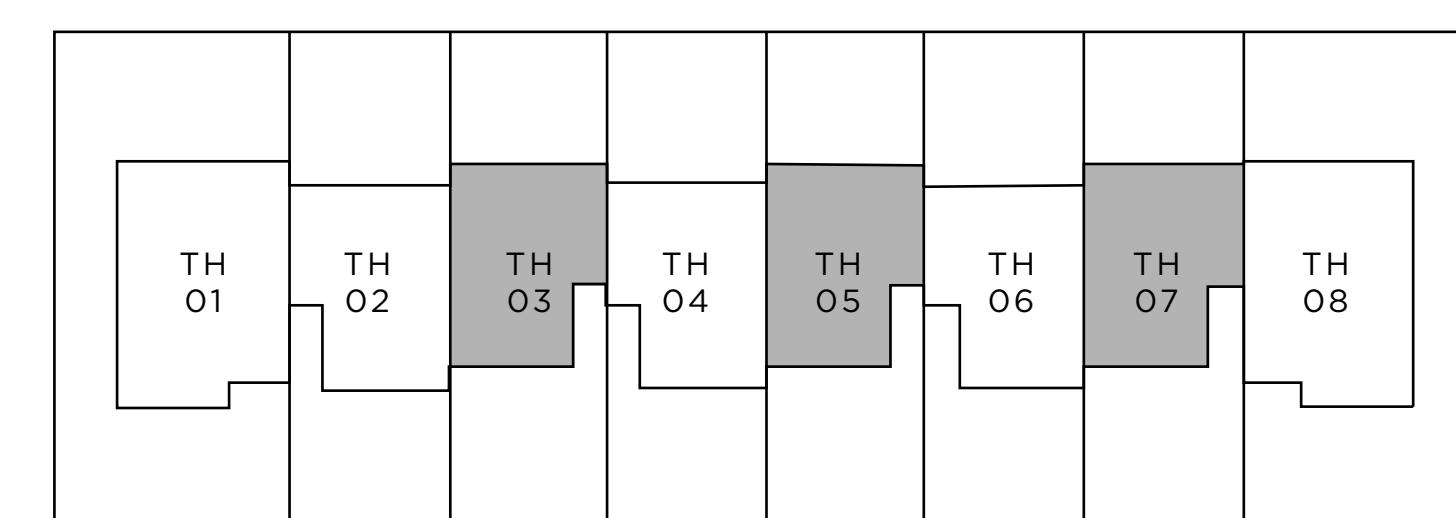

8 PLEX  
STREET SIDE

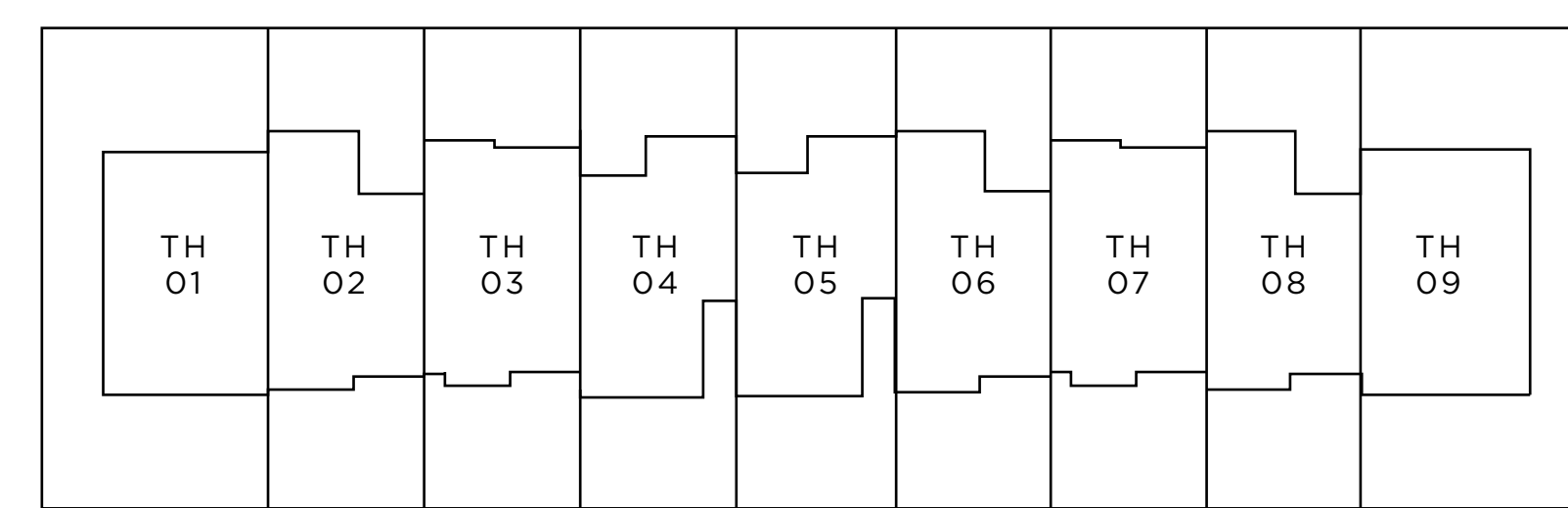

9 PLEX  
STREET SIDE

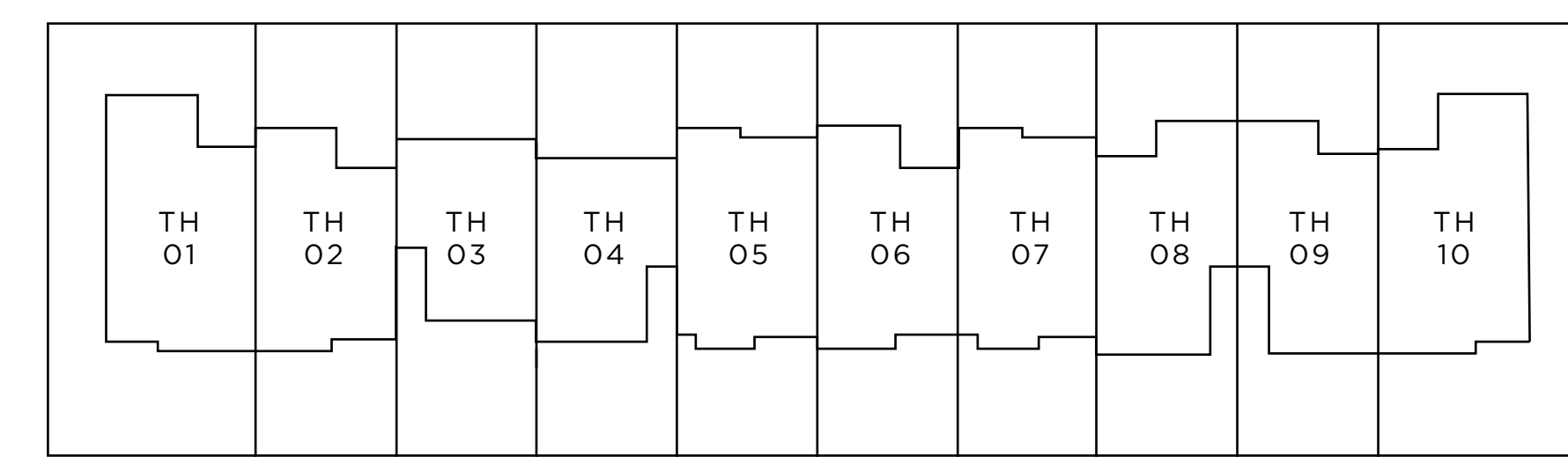

10 PLEX  
STREET SIDE



GROUND FLOOR

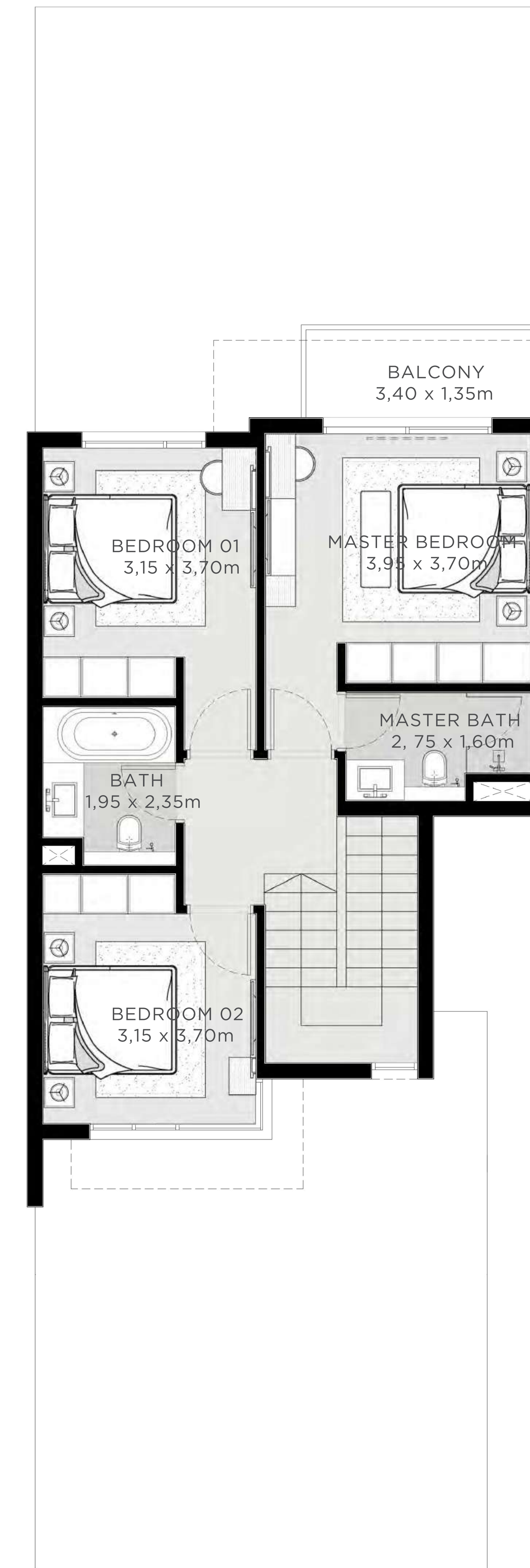

FIRST FLOOR

FLOOR PLAN 1. All dimensions are in imperial and metric, and measured from finish to finish excluding construction tolerances. 2. All materials, dimensions, and drawings are approximate only. 3. Information is subject to change without notice, at developer's absolute discretion. 4. Actual area may vary from the stated area. 5. Drawings not to scale. 6. All images used are for illustrative purposes only and do not represent the actual size, features, specifications, fittings, and furnishings. 7. The developer reserves the right to make revisions / alterations, at it's absolute discretion, without any liability whatsoever.